

# OE421 Compact E Plus

Panel PC 21,5" - wall-mounted



- High-resolution, bright 21.5" industrial LED screen
- Durable multi-touch glass
- CPU, Intel x6413E Quad Core with Turbo boost
- Dual 10/100 Mbit LAN
- RS232/RS422/RS485
- Wide temperature range
- Passive cooling, completely, no moving parts
- Fully enclosed aluminium unit
- IP65 all around, waterproof M12 connectors
- Quick and easy wall-mounting
- High reliability and long service life
- 5-year warranty

**The OE421 Compact E Plus is a fully enclosed, attractive and durable Panel PC for wall mounting. The enclosure is made of aluminium and its robust construction, together with M12 connectors, makes it washdown-proof all around. It has a wide temperature range, and the CPU, memory module and storage media are coated with a lacquer that provides extra protection against condensation, other moisture and conductive particles. It has a modern, stylish and compact design, making it ideal for placement in public areas.**

OE421 Compact E Plus is designed for use when a well-encapsulated and robust wall-mounted Panel PC with high performance and good connectivity is required. It is passively cooled with no moving parts, i.e. no fan or moving storage media. It is designed for a long technical life and has a high resistance to chemical and mechanical stresses such as shocks and vibrations.

OE400 Compact E Plus series has a high-resolution display, multi-touch functionality and comes with an efficient and power-saving Intel x6413E Quad Core with Turbo Boost. There are extensive options for connecting accessories and peripheral equipment via various types of serial ports, Ethernet and USB connections. OE400 Compact E Plus can be mounted quickly and easily using the supplied wall bracket, and there are several mounting options, such as standard VESA100 or VESA200x100.

*Industrial computers in the OE400 series are available in three different screen sizes: 10.1", 15.6" and 21.5". All models are PC-based and can run a variety of operating systems and software for presentation, monitoring, control and regulation. Examples of areas of application include machine control, building automation, manufacturing, chemical and food industries, water and sewage facilities, infrastructure, etc.*

# Panel PC

## - Technical data

### Hardware

#### Processor

Energy-efficient Quad Core Intel x6413E CPU at 1.5 GHz with Turbo Boost for increased performance. The CPU and motherboard are wide-temperature rated and have a protective coating.

#### Internal memory

Up to 32 GB DDR4 SDRAM in two easily replaceable, wide-temperature and protective-coated SODIMM modules.

#### Graphics/TFT/Display

21,5" TFT screen with 1920 x 1080 pixels with 16,2 millions colours and a brightness of 300 nit.

#### Storage System

Internally, there is space for a wide-temperature, protective-coated M.2 2280 SSD module with up to 960 GB.

#### Touch Screen

Chemically toughened front glass with projected capacitive touch function that supports up to 10 touch points. USB-connected touch function, Windows compatible.

#### Non-Battery Start

The unit can start without a CMOS battery, which is only required to maintain the correct clock and date.

#### Network Start

Can be started from the network without any support from its own storage media.

#### Expansion Options

The device has an internal half-length slot for MiniPCIe cards for WIFI or 4G/5G solutions.

### Software

#### Operating System

Windows 10/11 Pro, Windows 10/11 IoT Enterprise or Debian Linux. The hardware is also supported by several other operating systems.

#### BIOS

Reprogrammable 64 Mbits Flashprom. Uses BIOS software from AMI. Operates independently of the battery and supports media-free network start-up.

### Environment

#### Temperature

Operating: -25 to 55°C

Storage: -25 to 70°C

#### Chassis

Sturdy front made of saltwater-resistant aluminium and chemically toughened glass, with durable MS polymer seals, entire enclosure spray and dust resistant to IP65.

#### Humidity

Withstands 10-90 % relative humidity, non condensing.

#### Cooling

The unit is completely passively cooled without a fan or other moving parts. It only needs space for a self-circulating air flow on all sides of the enclosure to achieve satisfactory cooling.

#### EMC

The product is CE marked and approved per the EU LVD and following standards: EN 61000-6-3: 2001, EN 55022: 1998 class A, EN 55024:1998, -A1: 2001, EN 61000-4-2, -3, -4, -5, -6.

### Mounting

#### Models

Available for wall-mounting with built-in VESA100 mount or easy-to-install wall mount that also provides VESA200x100.

#### Measurements and Weight

547.4 x 344 x 45 mm (WxHxD)

Weight: 8.6 kg

#### Color

The front of the unit is made of glass with a black frame around the display section as standard. To protect the edge of the glass surface, there is a natural anodised aluminium barrier around the entire outer part of the front. The back is also made of natural anodised aluminium.

# Panel PC

## - Block diagram

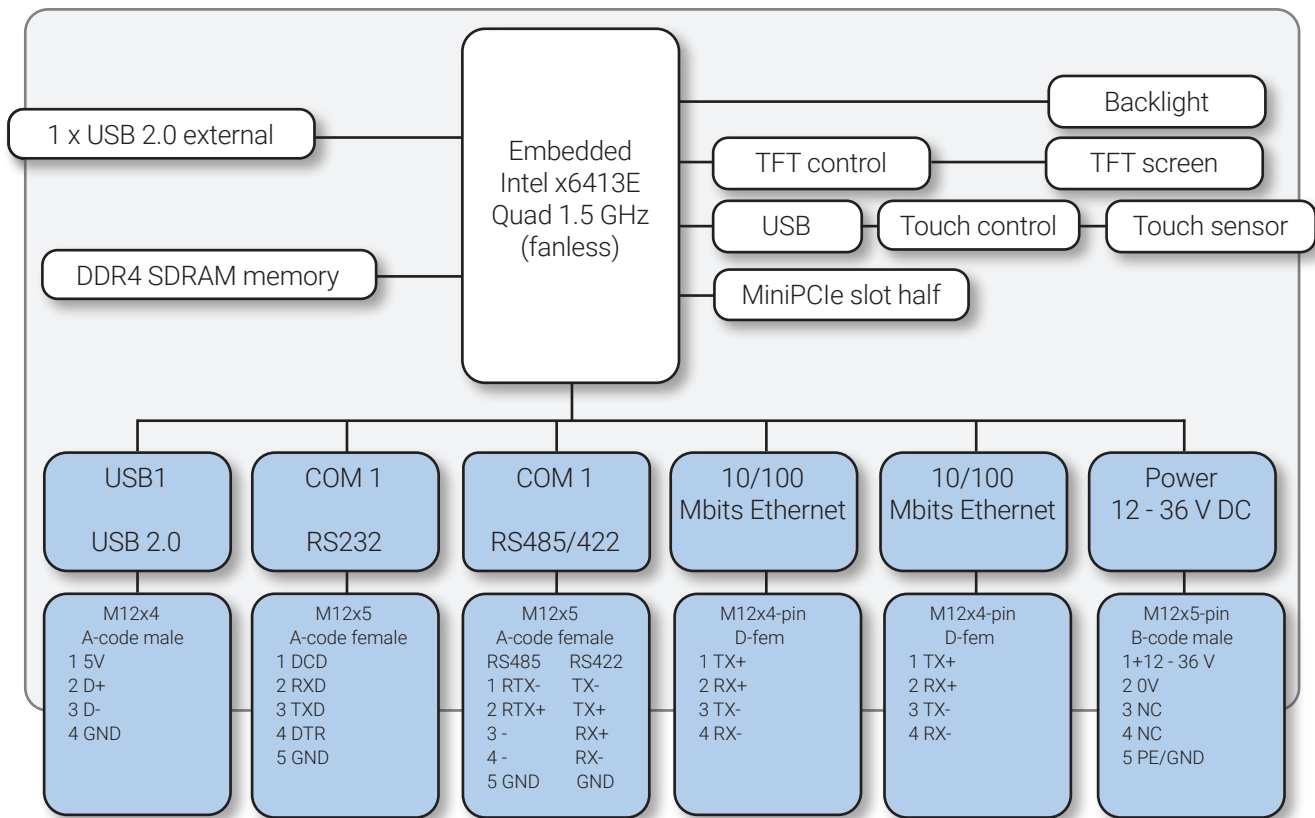

## Connections

### Network

Dual independent 10/100 Mbit Ethernet connections via M12 connectors, D-coded industrial standard.

### RS232/RS485

ESD-protected RS232 combined with the option of RS485/422 with 2- or 4-wire connection via M12 connector.

### USB

1 external 480Mbit according to 2.0 via M12 connector. One USB 2.0 service port under cover on left side.

### Power Supply

24 V DC, accepts 12-36 V DC.

Power consumption max 55 W.

## Connectors

### Below (from left to right)

Power	5-pin M12 B-kod male
LAN1	4-pin M12 D-kod female
LAN2	4-pin M12 D-kod female
RS232/485	5-pin M12 A-kod female
USB 2.0	4-pin M12 A-kod male

## Options/Modifications

- Wireless LAN 2,4GHz BG eller 2,4/5GHz ABGN
- External power supply 110/220 V AC
- Customised models can be produced on request
- Wall mount

## Dimensions and Mounting information

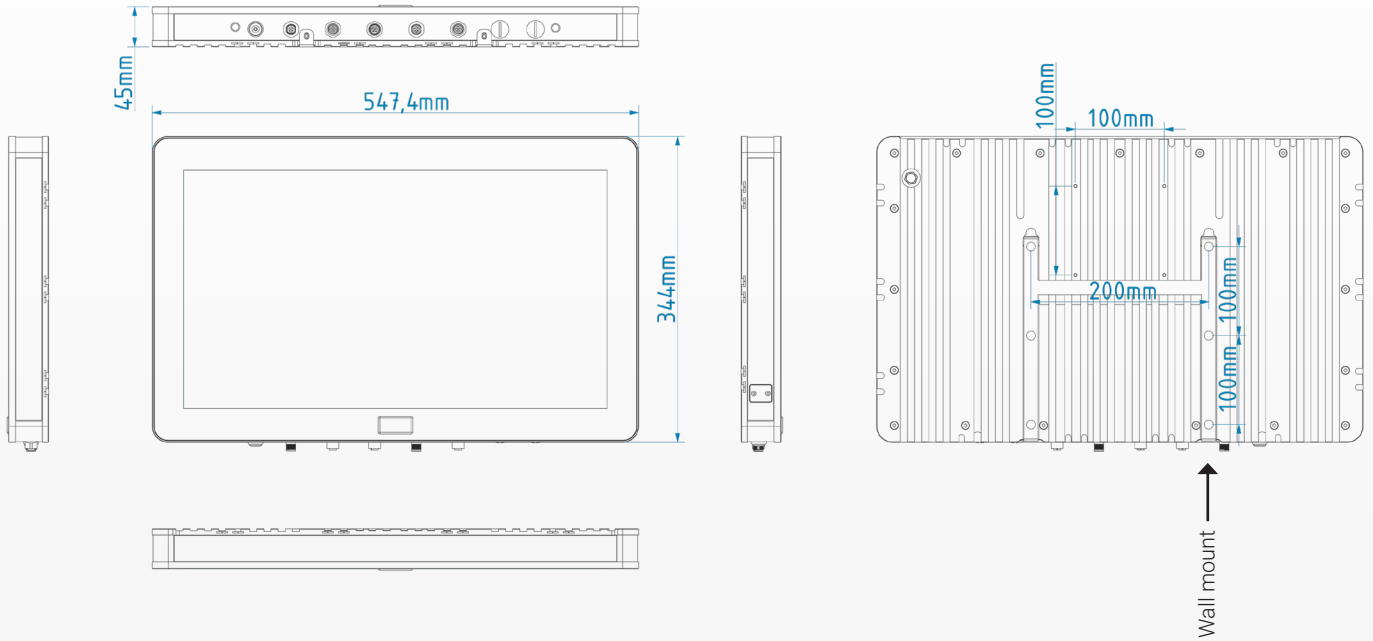

## Ordering information

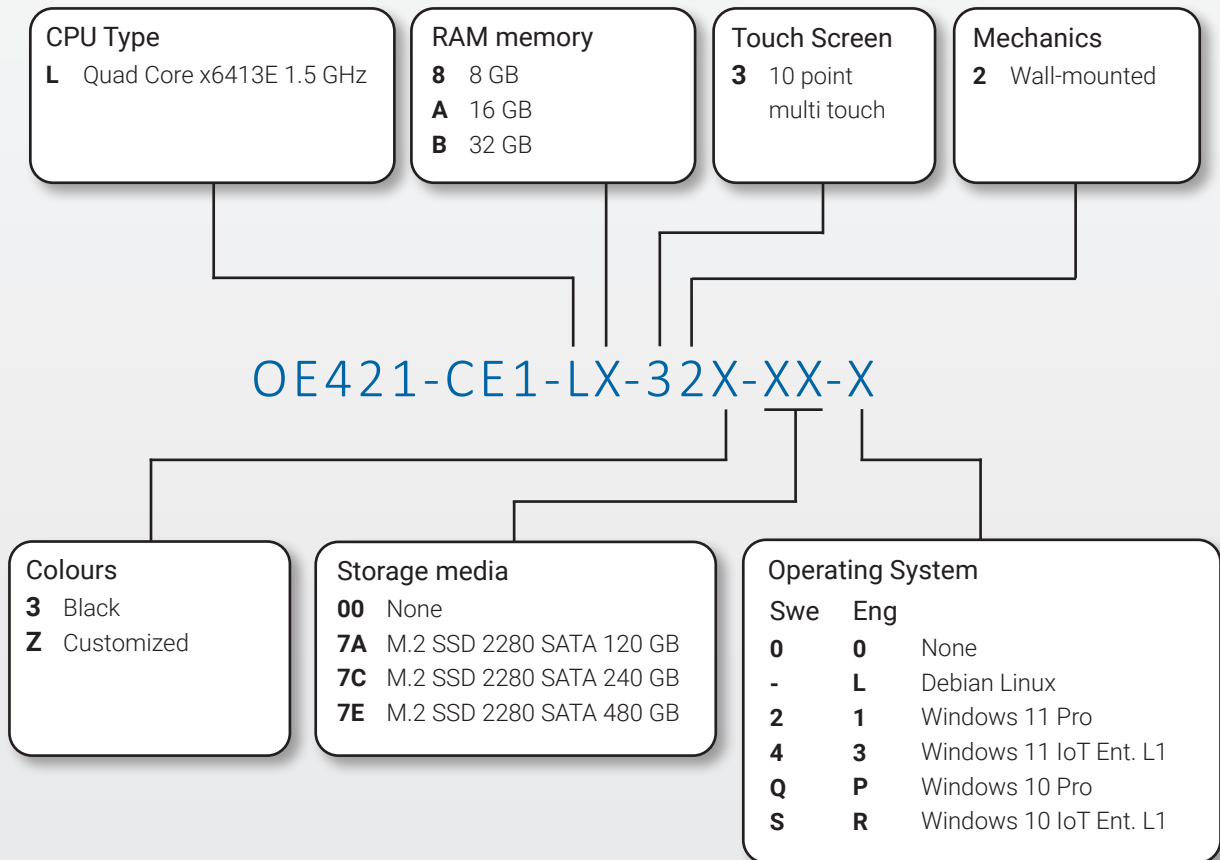

**Mailing address:**  
 PO BOX 174  
 SE-245 22 Staffanstorps  
 Sweden  
 Phone: +46 (0)46-25 30 40  
 E-mail: info@kentima.com

**Visiting address:**  
 Kastanjevägen 4  
 245 44 Staffanstorps  
 Sweden  
 www.kentima.com